

**HYDRECO**

a member of **DAIKIN** group

**HP001**









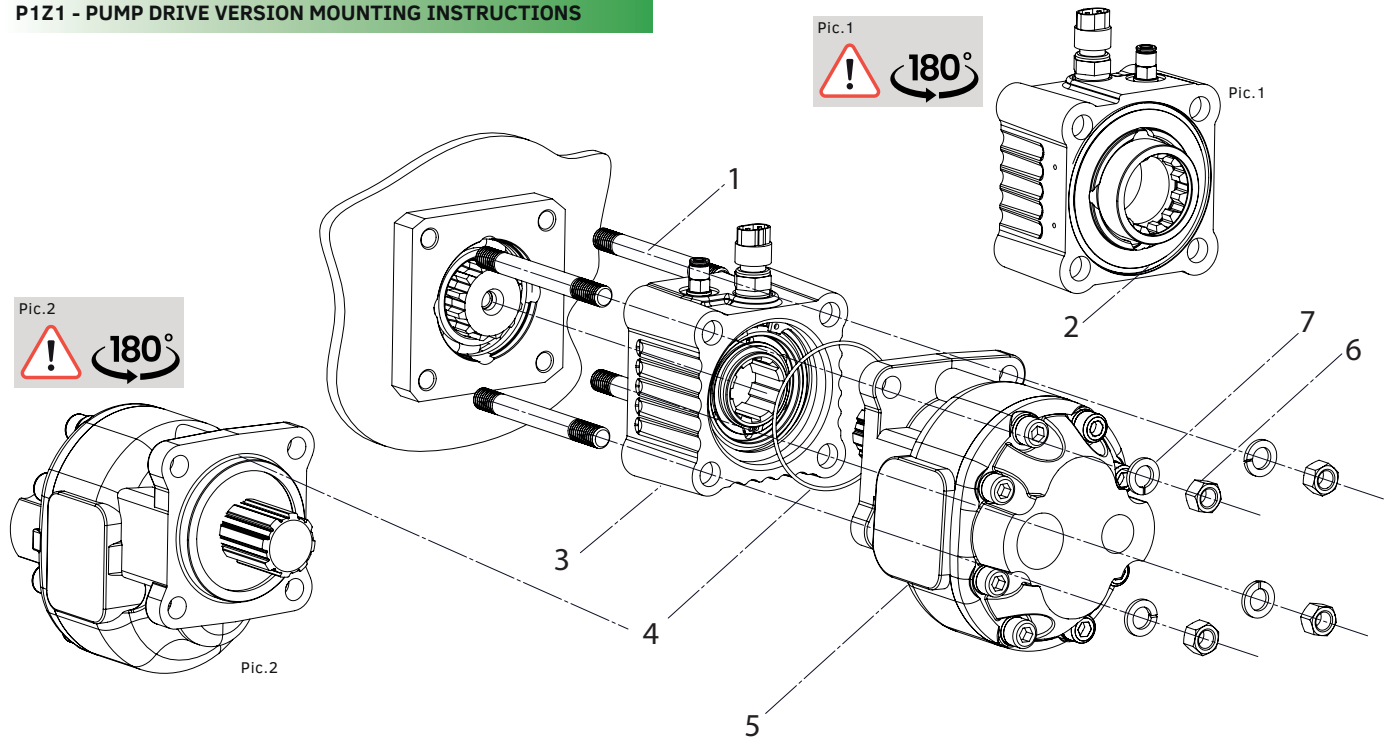











COAXIAL PTO FOR GEARBOX



**INSTALLATION MANUAL**









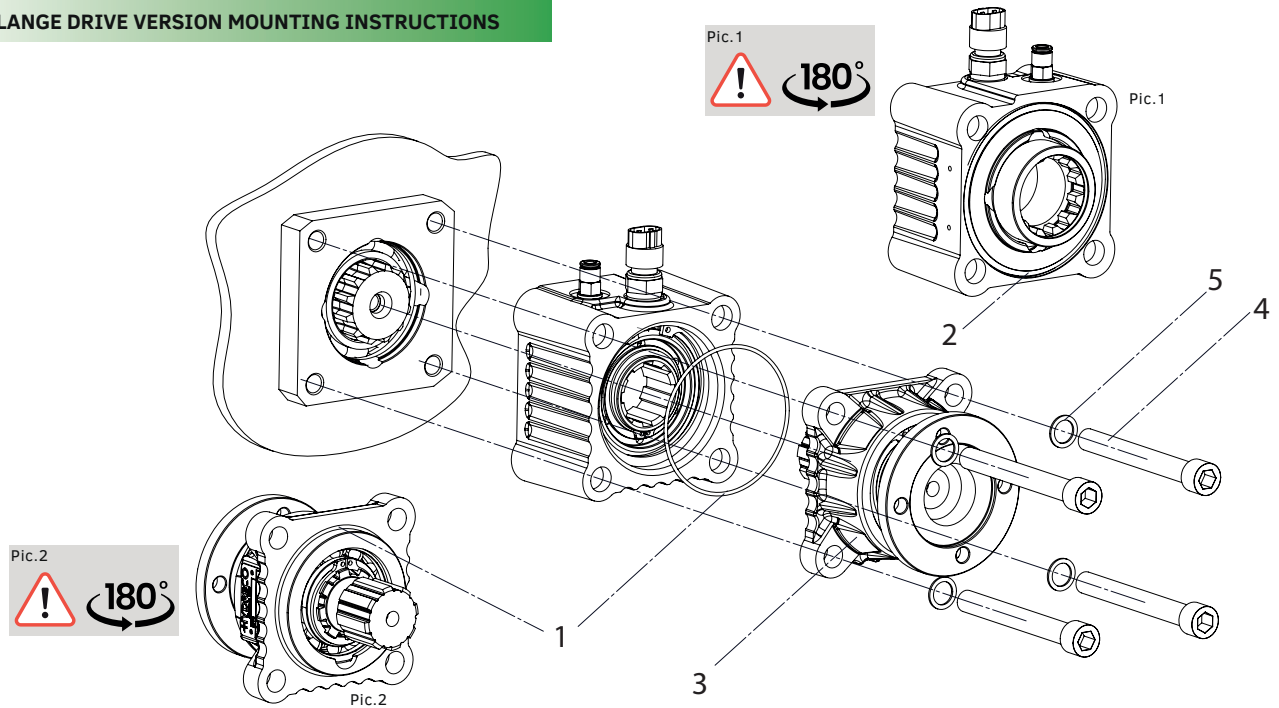





**P1Z1 - PUMP DRIVE VERSION MOUNTING INSTRUCTIONS**



- 1)   Inserire i 4 prigionieri "1" sul cambio o adattatore e serrare a 20Nm.  
 Insert the 4 studs "1" on the gearbox or adapter and tighten at 20Nm.
  
- 2)   Controllare che la guarnizione O-Ring "2", fornita insieme alla presa di forza, sia collocata correttamente nella propria sede.  
 Please check that the O-Ring gasket "2", supplied with the power take-off, is correctly positioned in its seat.
  
- 3)   Inserire la presa di forza "3" sui prigionieri.  
 Install the PTO "3" on the studs.
  
- 4)   Collocare la guarnizione O-ring "4" sul centraggio della pompa "5".  
 Place the O-ring gasket '4' on the spigot of the pump "5".
  
- 5)   Montare la pompa sulla presa di forza "5".  
 Assemble the pump onto the power take-off "5".
  
- 6)   Inserire i dadi "6", insieme alle rondelle "7", e serrare a 70Nm.  
 Insert the nuts "6", along with the washers "7", and tighten at 70Nm.
  
- 7)   Ripristinare l'olio del cambio, e controllarlo dopo aver fatto girare il cambio e la presa di forze per alcuni minuti.  
 Refill the gearbox oil and check it after a few minutes of operation of the gearbox and the power take off.

**P1Z1 - FLANGE DRIVE VERSION MOUNTING INSTRUCTIONS**



- 1)   Inserire la guarnizione O-Ring "1" sul centraggio del kit flangia "3".  
 Place the O-Ring gasket '1' on the spigot of the flange kit "3".
  
- 2)   Controllare che la guarnizione O-Ring "2", fornita insieme alla presa di forza, sia collocata correttamente nella propria sede.  
 Please check that the O-Ring gasket "2", supplied with the power take-off, is correctly positioned in its seat.
  
- 3)   Inserire il kit flangia sulla presa di forza.  
 Insert the flange kit onto the power take-off.
  
- 4)   Collocare il gruppo presa di forza e kit flangia, insieme alle viti "4" e alle rondelle "5", in battuta sul piano cambio/kit adattatore e serrare le viti a 55Nm.  
 Place the power take-off assembly and flange kit assembly, along with the screws '4' and washers '5', tied to the gearbox/flange adapter surface and tighten the screws to 55Nm.
  
- 5)   Ripristinare l'olio del cambio, e controllarlo dopo aver fatto girare il cambio e la presa di forze per alcuni minuti.  
 Refill the gearbox oil and check it after a few minutes of operation of the gearbox and the power take off.

Supported by a worldwide network



## CONTACT INFORMATION

### EMEA

<b>GERMANY</b>	Hydreco Hydraulics GmbH, Straelen (NRW)	☎ +49 283494303-41	✉ info-de@hydreco.com
<b>ITALY</b>	Hydreco Hydraulics Italia Srl, Vignola (MO)	☎ +39 059 7700411	✉ sales-it@hydreco.com
<b>ITALY</b>	Hydreco Hydraulics Italia Srl, Parma (PR)	☎ +39 0521 1830520	✉ sales-it@hydreco.com
<b>ITALY</b>	Hydreco Srl, San Cesario S/P (MO)	☎ +39 059 330091	✉ cylinders@hydreco.com
<b>NORWAY</b>	Hydreco Hydraulics Norway AS, Nittedal	☎ +47 22909410	✉ post-no@hydreco.com
<b>UK</b>	Hydreco Hydraulics Ltd, Poole, Dorset	☎ +44 (0) 1202 627500	✉ info-uk@hydreco.com

### AMERICAS

<b>NORTH/LATIN</b>	Hydreco Inc / Continental Hydraulics Inc, Shakopee (MN)	☎ +1 952 895 6400	✉ sales@conthyd.com
--------------------	---	-------------------	---------------------

### APAC

<b>AUSTRALIA</b>	Hydreco Hydraulics Pty Ltd, Seven Hills (NSW)	☎ +61 2 9838 6800	✉ sales-au@hydreco.com
<b>AUSTRALIA</b>	Hydreco Hydraulics Pty Ltd, Welshpool (WA)	☎ +61 8 9377 2211	✉ reception-wa@hydreco.com
<b>INDIA</b>	Hydreco Hydraulics India Private Ltd, Bangalore	☎ +91 80 67656300	✉ sales-in@hydreco.com

