

Technical Data Sheet



PA4800 SERIES POWER TAKE-OFF

Extra Heavy Duty Side Mounted Hotshift Power Take Off

The 4800 series is a truck mountable constant mesh hotshift PTO, actuated electrically by 12 or 24V, designed to suit the 10 bolt transmission openings on the MD and HD series Allison automatic transmissions fitted to trucks with gross vehicle weights greater than 3.5T.

This PTO has a high torque rating which is well suited to heavy duty applications.

Suits:

Allison MD 3050P, 3060P, 3070PT, 3550P, 3560P, HD 4060P, 4560P transmissions.

(Refer to the eGuide Configurator on www.hydreco.com for confirmation and details)

Product Features

- **New Improved Clutch Pack**
Providing longer life in harsh conditions.
- **New Piston Design**
Better sealing and lower friction for smooth movements.
- **Lower Profile**
Gives easier installation on narrow chassis'.
- **New Rear Cover That Can Fit In 3 Different Positions**
To allow seal changes in situ, resulting in more up time. While providing greater flexibility in fitting within confined spaces.
- **Solenoid has multiple positioning**
To better avoid obstructions during fitting.
- **One Gasket, One Hose Fitment**
Simple to install, resulting in lower setup costs.
- **Helix Angles Reversed**
Better loading prolongs bearing life.



HYDRECO
a member of **DAIKIN** group



www.hydreco.com

Technical Data Sheet

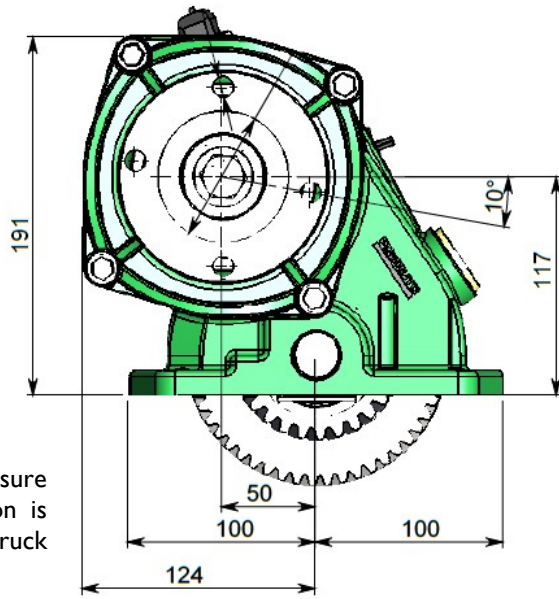

Note: The pressure switch connection is dependent on truck make and model.

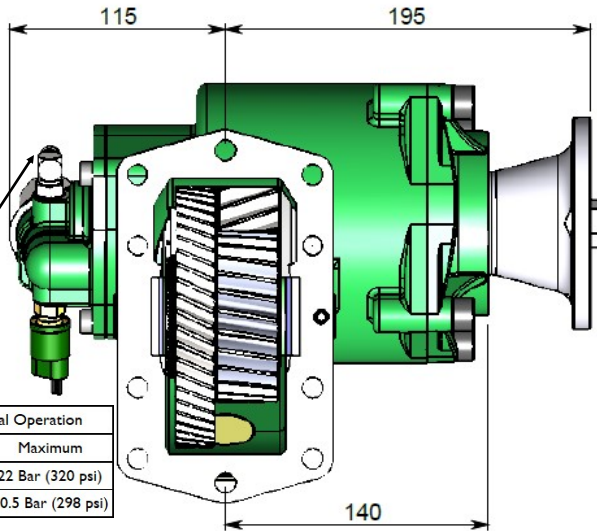

Mains Pressure During Normal Operation		
	Minimum	Maximum
3000 Series	12.4 Bar (180 psi)	22 Bar (320 psi)
4000 Series	12.4 Bar (180 psi)	20.5 Bar (298 psi)

PTO DESIGNATION CODES

4800 Series

PA 4823 JB LI I G 33 T

Identifier

PA = PTO Side Mount

PTO Series

4800

Ratio (3000/3000T/4000)

12 = 83%/101%/118%

23 = 88%/107%/125%

07 = 115%/141%/164%

10 = 137%/168%/196%

Other ratios available on request, subject to MOQ.

Gear Type

JB

Build

L1 = Left side of transmission, Bias to bottom

R2 = Right side of transmission, Bias to top

I = Centre to front

(Position of gear in transmission)

Engagement Type

F = Electric / Hydraulic 12V

G = Electric / Hydraulic 24V

J = Hydraulic - Ready for remotely mounted control kit

L = J + 12V Control Kit (CK182C)

M = J + 24V Control Kit (CK182D)

Output Type

23 = 8T Ø36 DIN 5462 Spline - Female and DIN Mount

26 = 14T 12/24 30° Spline + SAE C 2 & 4 Bolt Mount

33 = 17T 12/24 30° Spline + 1410 Flange

Other outputs available on request, subject to MOQ.

Manufacturers Code

T = With Mounting Kit & Loom Kit

Technical Specifications		4812	4823	4804	4807	4810
Ratings & Service Parts						
Ratio for 3000 Series (Left & Right Opening)		82.54%	87.80%	96.67%	115.32%	137.25%
Ratio for 3000 Series (Top & Side Opening)		100.75%	107.17%	117.99%	140.75%	167.53%
Ratio for 4000 Series		117.74%	125.25%	137.89%	164.49%	195.79%
PTO Torque (standard rating)	Nm (ft.lb)	655 (485)	655 (485)	655 (485)	655 (485)	600 (442)
PTO Torque * (I Mount Pad Use)	Nm (ft.lb)	470 (345)	470 (345)	470 (345)	470 (345)	470 (345)
PTO Torque (Fire & Emergency)	Nm (ft.lb)	655 (485)	655 (485)	655 (485)	655 (485)	600 (442)
Output Shaft Rotation		Same As Engine				
Approximate Bare Mass	kg (lb)	23.5 (51.7)				
Mounting Kit		MK1163				
Mounting Gasket Kit		GK023				
Seal Kit		SK072C				
Bearing Kit		BK072C				



Important Note

Allison Transmission Gear Max. Torque Loading	
Single Mount Pad Use	660Nm
Fire & Emergency Vehicle	910Nm
Both Mount Pads Used	930Nm

Note: For full details refer to the owners manual or the eGuide configurator found at www.hydreco.com/solutions/on-road

* Max Torque output to not overload Allison 3000 series transmission gear (refer to Important Note).

Doc: PA4800—02/24



HYDRECO
a member of **DAIKIN** group



www.hydreco.com