

ECU SERIES

CANopen
CONTROLLERS RANGE



ECU GENERAL DESCRIPTION

The ECU device is the new Hydreco CANopen controller with the latest generation electronics, conceived for mobile application. It is available as master or slave unit, ensuring flexibility and modularity to the control system adding the network all the necessary I/O resources and expansions to fit all the needed functions by machine manufacturers.

The ECU master controller is programmable through the common PLC programming languages used in industrial automation, so it offers the opportunity to readapt and reuse the source code already created in Ladder, ST, IL, SFC, Function Block.

IEC61131-3 LogicLab software environment is the tool used for programming, debugging, simulation, setting and modifying parameters, downloading the application on the unit, updating firmware and connecting the ECU for "real time" monitoring during field tests

The controller parameters setting is operated through laptop in LogicLab environment, via USB cable with and a four ways M12 male connector installed on the back of the controller.



ECU DIMENSIONAL DRAWING

Hydreco Hydraulics reserves the right to update the information and data contained in this catalogue at any time without notice

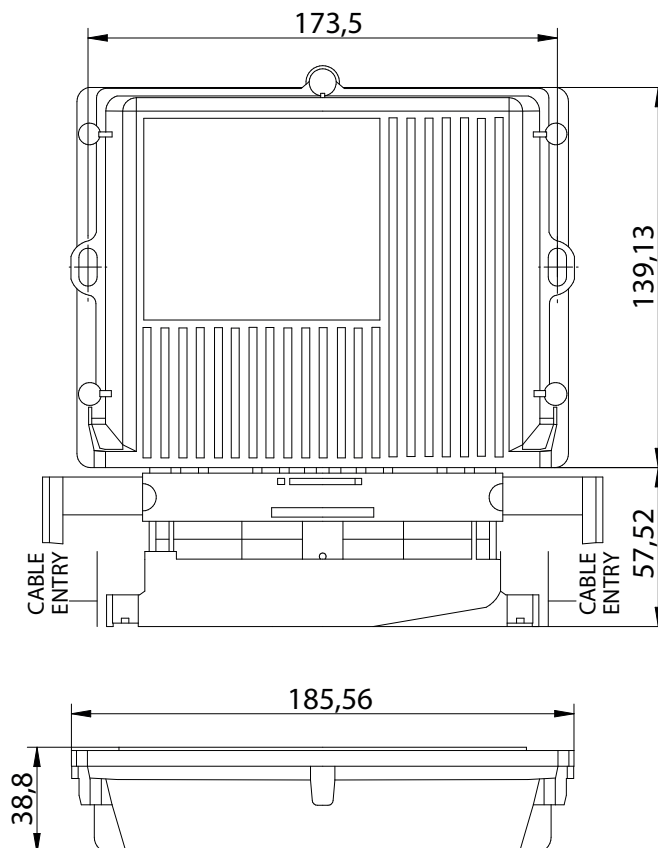

TECHNICAL FEATURES

Powersupply:	8-32VDC
Power ON consumption:	16mA@24VDC, 20mA@12VDC (no load)
Operating temperature:	-40÷85 °C
IP Protection degree:	IP6K8 according to ISO20653:2013
MCU:	ARM Cortex M33 Clock 160MHz (STM32U5xx)
Case :	Die-cast aluminum housing
Weight:	0,72Kg
MCUFlash Memory:	1MB
External Flash Memory	16MB
MCURAM:	786KB
External RAM:	4MB
EEPROM:	32KB
CAN Bus:	CANOpen protocol
Connections:	N.1 APTIV / DELPHI 56PIN SICMA male connector
Master usage:	IEC61131-3 programming languages
Slave usage:	EDS file
Programming:	IEC61131-3 Logilab software environment
Cycle time:	down to 2ms
EMC:	UNECE 10R06
IP with mating connector:	IP68

I/O DATA AND BLOCK DIAGRAM

N. 10	Analog/digital inputs (0..25mA, 0..5V, High-side, Low-side) N.4 of them for Frequency / RPM measures (max. 2KHz)
N. 2	Analog/digital inputs, integrated current source (0..23mA) and programmable (0..25mA, 0..5V, High-side, Low-side)
N. 1	CAN bus
N. 4	PWM High-side outputs with currents feedback (4A max.) autodetection and short circuit protection
N. 18	PWM High-side outputs (4A max.) with short circuit protection
N. 3	PWM Low-side outputs with currents feedback (4A max.) autodetection and short circuit protection (can be used as current feedback for PWM high-side outputs)
N. 1	5VDC/100mA OUT for sensor supply

*Total ECU output load max current must be 30A (Each group of BTS MOSFET 12A max)

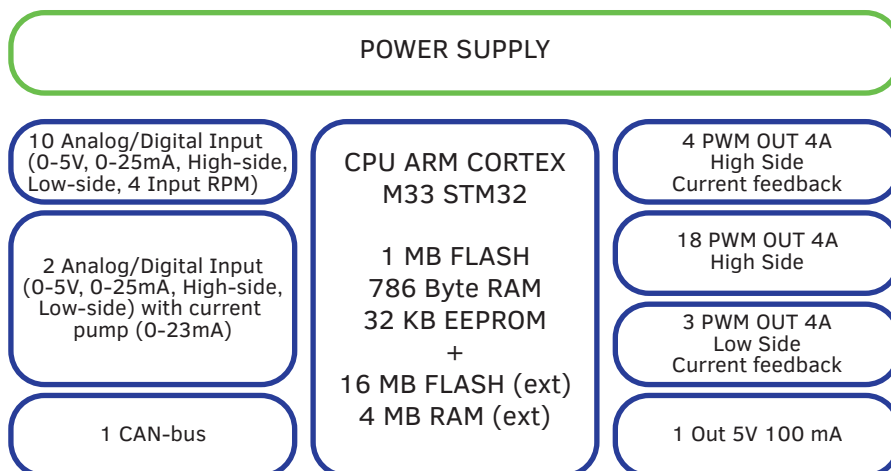

M12 4-ways USB MALE CONNECTOR

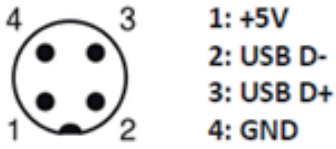

APTIV / DELPHI 56PIN SICMA MALE CONNECTOR

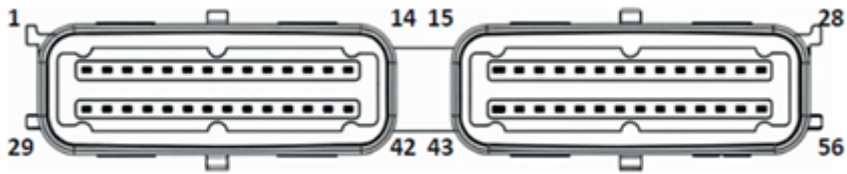

1 OUT1	8 OUT8	29 VBAT1	36 IN2	15 OUT15	22 OUT22	43 IN7	50 VBAT6
2 OUT2	9 OUT9	30 VSUP	37 IN3	16 OUT16	23 LS_OUT1	44 IN8	51 IN11
3 OUT3	10 OUT10	31 GND	38 VBAT3	17 OUT17	24 LS_OUT2	45 IN9	52 IN12
4 OUT4	11 OUT11	32 CANH	39 IN4	18 OUT18	25 LS_OUT3	46 VBAT5	53 CANH
5 OUT5	12 OUT12	33 CANL	40 IN5	19 OUT19	26 NC	47 IN10	54 CANL
6 OUT6	13 OUT13	34 VBAT2	41 IN6	20 OUT20	27 +5V_OUT	48 IN13	55 GND
7 OUT7	14 OUT14	35 IN1	42 VBAT4	21 OUT21	28 D+	49 IN14	56 AN_GND

MATING CONNECTOR	
BODY	APTIV PPI0001258
LOCKING CAM	APTIV 211A567007
COVER	APTIV 211A560008
PIN	APTIV 211CC2S2160P

Supported by a worldwide network



CONTACT INFORMATION

EMEA

GERMANY	Hydreco / Till, Helmstedt (NI)	+49 535155860	info@hydreco.de
ITALY	Hydreco Hydraulics Italia Srl, Vignola (MO)	+39 059 7700411	sales-it@hydreco.com
ITALY	Hydreco Hydraulics Italia Srl, Parma (PR)	+39 0521 1830520	sales-it@hydreco.com
ITALY	Hydreco Srl, San Cesario S/P (MO)	+39 059 330091	cylinders@hydreco.com
NORWAY	Hydreco Hydraulics Norway AS, Nittedal	+47 22909410	post-no@hydreco.com
UK	Hydreco Hydraulics Ltd, Poole, Dorset	+44 (0) 1202 627500	info-uk@hydreco.com

AMERICAS

NORTH/LATIN	Hydreco Inc / Continental Hydraulics Inc, Shakopee (MN)	+1 952 895 6400	sales@conthyd.com
--------------------	---	-----------------	-------------------

APAC

AUSTRALIA	Hydreco Hydraulics Pty Ltd, Regents Park (NSW)	+61 2 9838 6800	sales-au@hydreco.com
AUSTRALIA	Hydreco Hydraulics Pty Ltd, Welshpool (WA)	+61 8 9377 2211	reception-wa@hydreco.com
INDIA	Hydreco Hydraulics India Private Ltd, Bangalore	+91 80 64536200	sales-in@hydreco.com

